

MASTERFLEX® B/T® Pump 940-1610

OPERATING MANUAL:

**B/T® RAPID-LOAD
PERISTALTIC PUMPS
AND DRIVE**

Model Numbers

940-1610

940-1615

A-1299-5111
Edition 01

TABLE OF CONTENTS

Title	Page
SAFETY PRECAUTIONS	3
INTRODUCTION	4
APPLICATION DATA	4
GENERAL DESCRIPTION	5
INSTALLATION AND SETUP	6
Pump Mounting Dimensions	7
TUBING TYPES	7
INSTALLING THE PUMP TUBING	8
REPLACING ROLLERS	9
OPERATION	9
MAINTENANCE	10
Replacement Parts	11
Cleaning	11
ACCESSORIES	12
SPECIFICATIONS	13
WARRANTY	16
PRODUCT RETURN	16
TECHNICAL ASSISTANCE	16

MASTERFLEX, B/T and RAPID-LOAD – Reg TM Cole-Parmer Instrument Co.

C-FLEX – Reg TM Consolidated Polymer Technologies, Inc.

NORPRENE, PHARMED and TYGON – Reg TM Norton Co.

PHARMAPURE– Reg TM Saint-Gobain

Trademarks bearing the © symbol in this publication are registered in the U.S. and in other countries.

SAFETY PRECAUTIONS

DANGER: *High voltages exist and are accessible. Do not remove cover of Drive or Controller. Use extreme caution when servicing internal components.*



CAUTION: *Risk of electric shock – this pump is supplied with a grounding conductor and grounding-type attachment plug. To reduce risk of electric shock, be certain that it is connected only to a properly grounded, grounding-type receptacle.*



WARNINGS: *Tubing breakage may result in fluid being sprayed from pump. Use appropriate measures to protect operator and equipment.*



To reduce risk of injury, power must be removed from pump before removing or installing tubing. Fingers or loose clothing could get caught in drive mechanism. Do not operate this pump without cover or interlock door properly closed and latched. Rotating parts can cause serious injury.

To reduce risk of injury, do not pump materials hotter than 150 degrees Fahrenheit, (65.5°C).

WARNING: *Electrical connections and grounding (earthing) must conform to local wiring codes.*



Explanation of Symbols

CAUTION: *Risk of Danger. Consult Operator's manual for nature of hazard and corrective actions.*



CAUTION: *Risk of crushing. Keep fingers away from rotor while pump is in operation. Stop pump before loading or unloading tubing.*



CAUTION: *Hot Surface. Do not touch.*



CAUTION: *Risk of electric shock. Consult Operator's manual for nature of hazard and corrective actions.*



WARNING: PRODUCT USE LIMITATION

This product is not designed for, nor intended for use in, patient-connected applications, including, but not limited to, medical and dental use, and, accordingly, has not been submitted for FDA approval. If drive is used in a manner not specified in this manual the protection provided by the equipment may be impaired.

INTRODUCTION

This manual provides information for installing, operating and servicing the following models of MASTERFLEX[®] B/T[®] RAPID-LOAD[®] Peristaltic Pumps and Drive.

MODEL	TYPE
-------	------

940-1610	Pump with variable speed washdown motor and IP56 controller, 115V AC system.
----------	--

940-1615	Pump with variable speed washdown motor and IP56 controller, 230V AC system.
----------	--

The unique design of these peristaltic pumps provides a greatly simplified means for rapid loading and changing of tubing. In addition, the following features are incorporated:

Pumps up to 10 GPM.

Uses continuous tubing to ensure a sanitary and non-contaminating system.

Fluid contacts only the tubing.

Handles wide range of viscosities.

Several different size tubing and formulations can be used.

Washdown motor and IP56 controller is provided.

APPLICATION DATA

The gentle peristaltic action of these pumps is ideal for pumping highly viscous and shear-sensitive liquids. These pumps are also ideally suited for use where sterile conditions and purity are required. Toxic and hazardous fluids can be pumped with the proper selection of MASTERFLEX PERFECT POSITION B/T tubing since the fluid contacts only the tubing and not the pump.

WARNING: *Tubing breakage may result in fluid being sprayed from pump. Use appropriate measures to protect operator and equipment.*



GENERAL DESCRIPTION

The RAPID-LOAD® B/T peristaltic pump (see Figure 1) is mounted on a base and attached to a NEMA 56C frame motor or IEC-72 71-14F130 frame motor (with foot mountings) through a 5.45:1 gear head and adapter. Depending on the model, the motor is either supplied or customer furnished and is attached to the adapter by four bolts and to the base by an additional four bolts. The controller is mounted on a bracket above the gear head. The bracket and controller can be removed and hung by two bolts at a location up to 10 ft. away. The controller incorporates a REV-OFF-FWD switch and a speed control.



Figure 1. RAPID-LOAD PUMP AND DRIVE

Due to its unique design, different MASTERFLEX PERFECT POSITION B/T tubing sizes can be accommodated by this RAPID-LOAD peristaltic pump.

For an indirect estimate of flow rate, a reflective element attached to the rotor has been provided for use with an optical tachometer. Point tachometer beam through front cover window and target the reflective element.

To obtain flow rate in mL/min., multiply tachometer rpm reading times the nominal flow per revolution value provided in TABLE 1 (**Note:** 37.85 mL = 1 U.S. liquid gallon).

The maximum recommended rotor speed is 321 rpm. The pump rotor can turn either clockwise or counterclockwise. When turning clockwise (FWD) the top connection is for suction and the bottom connection is for discharge. The 321 rpm speed is obtained from the standard 1725 rpm fractional horsepower motor through the 5.45:1 gear reduction. Faster speeds will increase flow, but will also considerably shorten average tubing life. (We cannot be responsible for pump performance when operated at speeds higher than 321 rpm.)

If the pump is to be operated with back-pressure on the discharge line greater than 5 PSIG, hose clamps or screw-type band clamps are recommended on the tubing connections on the discharge side of the pump. Silicone or C-FLEX® tubing, because of their highly elastic natures, can expand very quickly if back-pressure is present and could create leakage at the fittings if not securely retained. It is this same elastic nature, however, that makes them such excellent materials for this peristaltic type pump. NOPRENE® tubing yields longer life, especially under pressure. Do not attempt to use other materials in lieu of these, as pump performance could be severely compromised with possible damage to the pump. Refer to Table 1 for tubing recommendations.

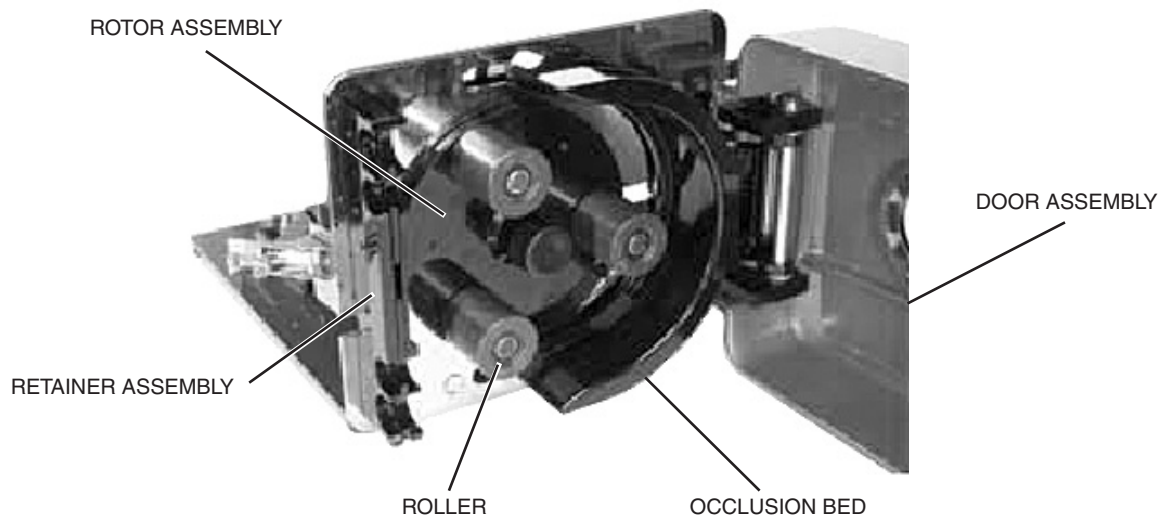

Figure 1. RAPID-LOAD PUMP AND DRIVE

INSTALLATION AND SETUP

These units should be placed on a flat surface such as a floor, bench or table and should be near an electrical power source. Be sure to check data plate for proper voltage rating(s).

NOTE: The controller and bracket can be removed and located up to 10 feet away. Secure the bracket using two bolts inserted through the keyhole slots.

PUMP MOUNTING DIMENSIONS

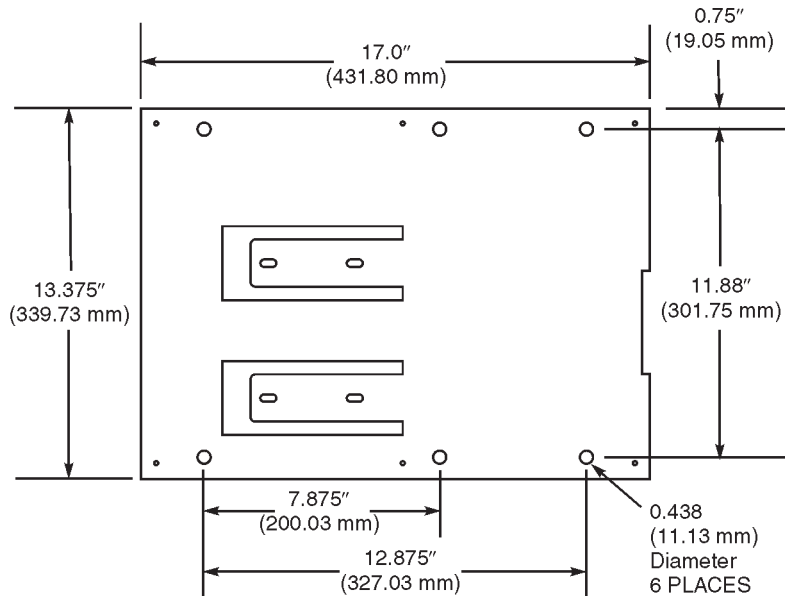

MODEL NOS. 940-1610, 940-1615

TUBING TYPES

Use only MASTERFLEX PERFECT POSITION B/T precision tubing with MASTERFLEX pumps to ensure optimum performance.

Use of other tubing may void applicable warranties.

NOTE: Use MASTERFLEX PERFECT POSITION B/T tubing. These pumps are designed to use PERFECT POSITION B/T tubing sizes 87 and 91 only. The tubing sizes refer to the last two digits of the MASTERFLEX PERFECT POSITION B/T tubing model number.

The following chart provides information for the various sizes of tubing.

Table 1

Characteristics	Tubing Size	
	B/T 87	B/T 91
Inside Dia. in (mm)	0.5 (12.7)	0.75 (19.05)
Outside Dia. in (mm)	1.0 (25.4)	1.25 (31.8)
Hose barb size in (mm)	1/2" (12.7)	3/4" (19.0)
Flow Range (with 321 rpm drive)	0.17-5.0 GPM (0.010-18.9 L/m)	0.37-10 GPM (1.40-37.85 L/m)
Nominal Flow Per Revolution	70.46 mL	141 mL
Maximum Vacuum	28.5 in Hg	32 in Hg
Maximum: Outlet Pressure	35 psi	30 psi
Flow ranges are approximate - calculated under the following conditions: 0 psi at inlet, 0.5 psi at outlet and water circulant at 72°F (22° C).		

INSTALLING THE PUMP TUBING

WARNING: *Power must be removed from pump before removing or installing tubing. Fingers or loose clothing could get caught in drive mechanism. Do not operate this pump without cover or interlock door properly closed and latched. Rotating parts can cause serious injury.*



1. Cut off power to the pump by disconnecting line cord or, if wired permanently, by removing the fuse. Do not assume that turning off the switch at the motor (or controller) is "safe enough."
2. Unlatch the locking clamp and open the cover.
3. Insert the tube in the appropriate upper tube retaining pocket (see Figure 2). Line up the "Perfect position" placement marks printed on the tube with the outside edge of the retainer assembly (see Figure 3).
4. Wrap the tubing around the rotor assembly and insert the tubing in the lower retaining pocket.
5. Close the cover and re-latch the locking clamp.
6. If the new tube must be cut from a length of approved replacement tubing, a minimum of 32 inches will be required for a new tube.

WARNING: *Do not operate this pump without cover or interlock door properly closed and latched. Rotating parts can cause serious injury.*



7. Restore power to the pump.

NOTE: Under some circumstances, tubing may creep into pump. If this problem occurs it can be remedied by installing a hose clamp or fitting immediately upstream of the upper retaining pocket.

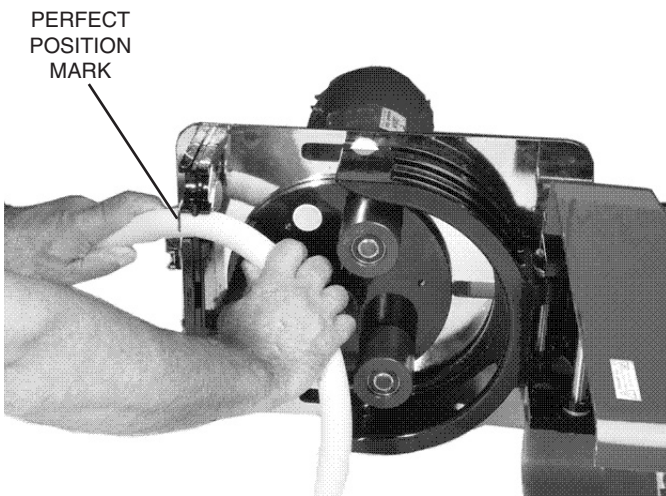

Figure 2. TUBING RETAINING POCKETS

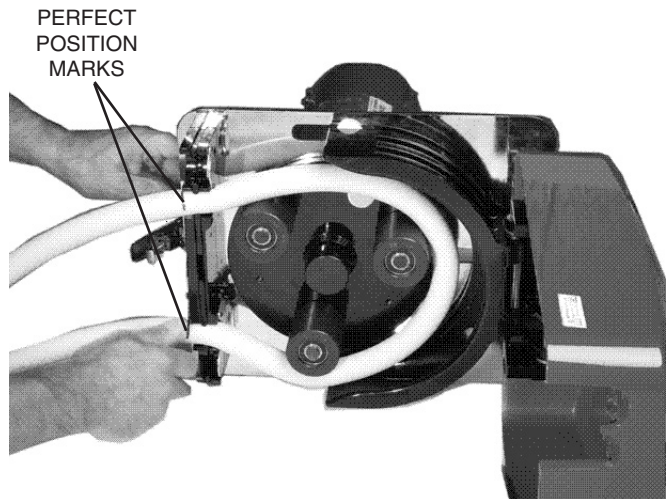
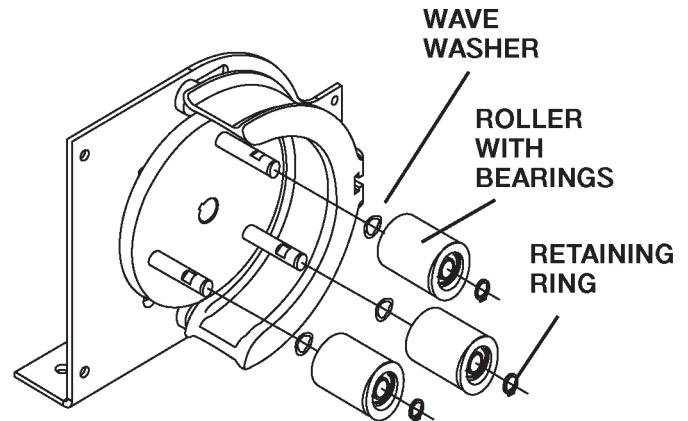

Figure 3. PERFECT POSITION MARKS

REPLACING ROLLERS

To replace rollers:

1. Using a retaining ring tool (Part Number 7585-06), remove the retaining rings from the ends of the roller axles and slide the rollers off. Take care to avoid opening the retaining rings too wide.
2. Check to be sure that the wave washers are installed on the axles against the rotor plate.
3. Slide the new rollers onto the axles, placing the ends with the flush bearing surface inward toward the rotor plate against the wave washers, and the etched ends with the recessed bearing surface outward toward the free ends of the roller axles.
4. Replace the retaining rings. You may have to push the rollers in to compress the wave washers to allow the retaining rings to engage the grooves in the axles.



EXPLODED ROLLER SUB-ASSEMBLY

OPERATION

Controller:

Models 940-1610 (115V model) and 940-1615 (230 V model) are supplied with an electronic controller (see Figure 4) for controlling pump speed.

1. Place FWD-OFF-REV switch in the desired position, clockwise (FWD) or counterclockwise (REV) direction.
2. Adjust SPEED control for the desired pump speed.

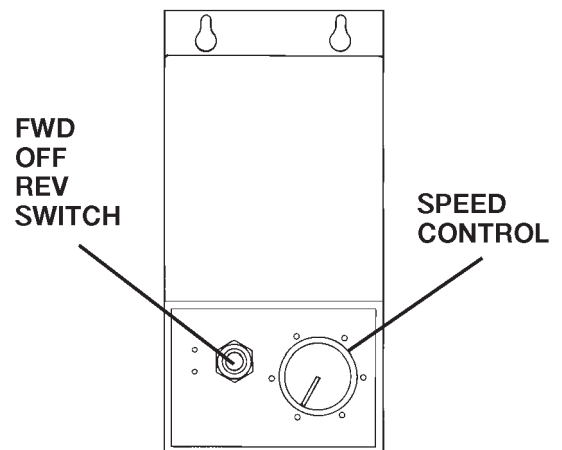

Figure 4. CONTROLLER

MAINTENANCE

Tools Required: Phillips screwdriver

Motor Brush Replacement Models 940-1610 and 940-1615

WARNING: *Power must be removed from motor before performing this procedure.*



1. Cut off power to the pump by disconnecting line cord or, if wired permanently, by removing the fuse. Do not assume that turning off the switch at the motor (or controller) is "safe enough."
2. To access the motor brushes, remove six screws securing the access plate and remove plate (see Figure 5).
3. Loosen screw terminal at top of brush housing and disconnect brush wire.
4. Press down on brush retainer to disengage tabs then rotate brush retainer slightly toward front of motor and remove brush retainer.
5. Slide brush assembly out of housing.
6. Install new brush assembly with brush wire toward rear of motor and spring assembly on top.
7. Insert brush retainer against brush springs and push down, then rotate retainer slightly toward rear of motor to engage tabs of retainer under rear edge of brush housing.
8. Attach brush wire to screw terminal at top of brush housing. Be sure wire is clear of access opening.
9. Attach cover plate with six screws.

Note: Always replace both brushes at the same time.

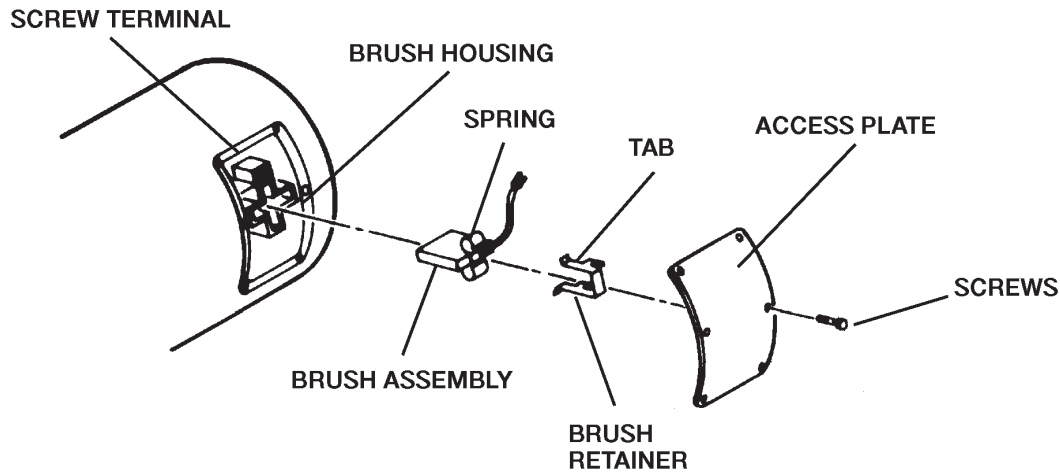

Figure 5. MOTOR BRUSH

Replacement Parts

The following list identifies the replaceable parts and includes the part numbers.

Description	Part Number	Qty per Unit
Motor Brush Set (only applicable to Model 940-1610)	A-4156-CR	1
Motor Brush Set (only applicable to Model 940-1615)	A-4158-CR	1
Door Assembly	108175-CR	1
Rubber Feet Kit (6 screws)	108655-CR	6
MASTERFLEX B/T Roller Kit	108656-CR	1
MASTERFLEX B/T Rotor Assembly/with Rollers	108024-CR	1
Window	108179-CR	1
Window Gasket	108183-CR	1
Shoulder Spacer Kit	108013-CR	3
Safety Switch Assy	108173-CR	1

Cleaning

Keep the drive enclosure clean with mild detergents. Never immerse nor use excessive fluid.

ACCESSORIES

All MASTERFLEX PERFECT POSITION B/T tubing formulations in sizes 87 and 91 can be used with this pump. Be sure tubing material matches application.

Description	Part Number	
Retaining Ring Tool	7585-06	
Extension Cable, 25 ft.	108657-CR	
PERFECT POSITION Pump Tubing	B/T 87	B/T 91
Silicone - 10 ft. (3.0 m), Platinum cured	K-96510-87	K-96510-91
Silicone - 10 ft. (3.0 m), Peroxide cured	K-96400-87	K-96400-91
BioPharm silicone - 25 ft. (7.6 m), Platinum cured	K-96422-87	K-96422-91
BioPharm Plus silicone - 25 ft. (7.6 m), Platinum cured	K-96442-87	K-96442-91
C-FLEX - 10 ft. (3.0 m)	K-06424-87	K-06424-91
PharMed [®] BPT - 25 ft. (7.6 m)	K-06508-87	K-06508-91
PharMed [®] BPT - 3 ft. (0.9 m)	K-95668-87	K-95668-91
PharmaPure [®] - 25 ft. (7.6 m)	K-06435-87	K-06435-91
Norprene [®] food - 25 ft. (7.6 m)	K-06402-87	K-06402-91
Norprene [®] food - 3 ft. (0.9 m)	K-06403-87	K-06403-91
TYGON [®] LFL - 25 ft. (7.6 m)	K-06429-87	K-06429-91
TYGON [®] LFL - 3 ft. (0.9 m)	K-06430-87	K-06430-91

SPECIFICATIONS

Output:

Pump Speed:	12 to 321 rpm
Torque output, maximum:	1100 oz-in (104 kg-cm)
Tubing compatibility:	Sizes 87 or 91
Flow Range:	Up to 10 GPM

Input:

Supply voltage limits:

Model 940-1610	90 to 130 Vrms @ 60 Hz
Model 940-1615	200 to 260 Vrms @ 50 Hz

Current, max:

Model 940-1625	8A, 1/4" × 1-1/4", fast acting
Model 940-1615	5A, 1/4" × 1-1/4", fast acting

Construction:

Dimensions:

Model 940-1610

16.5 in W × 14 in H × 22 in D
(41.9 cm W × 35.6 cm H × 55.9 cm D)

Model 940-1615

16.5 in W × 14 in H × 22 in D
(41.9 cm W × 35.6 cm H × 55.9 cm D)

Weight:

Model 940-1610	89 lbs (40.4 kg)
Model 940-1615	89 lbs (40.4 kg)

Enclosure Rating:

Model 940-1610	IP56 per IEC 60529
Model 940-1615	IP56 per IEC 60529

SPECIFICATIONS (cont.)

Construction (cont.)

Environment:

Operating Temperature: 0°C to 40°C (32°F to 104°F)

Storage Temperature: -20°C to 60°C (-4°F to 140°F)

Humidity:
(non-condensing) 10% to 90%

Altitude: Less than 2000 m

Chemical Resistance: Exposed material is painted aluminum, plastic and vinyl

Compliance: 115V: UL778, CSA C22.2 No. 108

230V: (for CE Mark)

Notes . . .

WARRANTY

Use only MASTERFLEX PERFECT POSITION B/T precision tubing with MASTERFLEX pumps to ensure optimum performance. Use of other tubing may void applicable warranties.

The Manufacturer warrants this product to be free from significant deviations from published specifications. If repair or adjustment is necessary within the warranty period, the problem will be corrected at no charge if it is not due to misuse or abuse on your part, as determined by the Manufacturer. Repair costs outside the warranty period, or those resulting from product misuse or abuse, may be invoiced to you.

The warranty period for this product is noted on the Warranty Card.

PRODUCT RETURN

To limit charges and delays, contact the seller or Manufacturer for authorization and shipping instructions before returning the product, either within or outside of the warranty period. When returning the product, please state the reason for the return. For your protection, pack the product carefully and insure it against possible damage or loss. Any damages resulting from improper packaging are your responsibility.

TECHNICAL ASSISTANCE

If you have any questions about the use of this product, contact the Manufacturer or authorized seller.

Barnant

1-800-637-3739 (U.S. and Canada only)
11 (847) 381-7050 (outside U.S.)
(847) 381-7050 (Local)
11 (847) 381-7053 (Fax outside U.S.)
(847) 381-7053 (Local Fax)
www.barnant.com
e-mail: barnant@barnant.com

ISO9001
REGISTERED
SUPPLIER